

POWER ACCESSORIES

TURNING WHEEL/TURNING POST ASSEMBLY

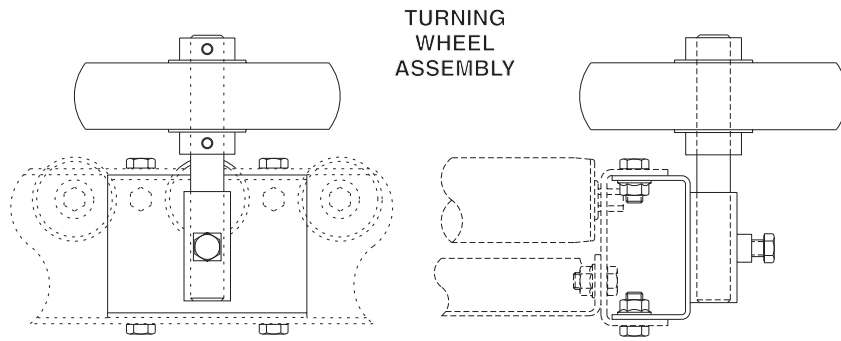

Turning wheel and turning post assemblies (turning post shown lower right) are commonly used in applications with converging or diverging spurs. These simple transition devices assist products with smooth transition to or from spur line.

SPECIFICATIONS

TW: 6" dia. x 1-1/2" wide face rubber wheel with 3/4" dia. bore; shaft is 3/4" dia. w/ locking collar positioned above and below wheel. Shaft adjusts vertically up/down to accommodate product height.

TP: 196S roller (medium duty) or 251S roller (heavy duty), both 6" BF mounted in 7 ga. frame assembly.

SPECIFY MODEL NUMBER PER EXAMPLE

TW-3.5

T(wheel or post*)-(frame depth or roller size**)

*Specify W for turning wheel or P for turning post.

**For turning wheel specify frame size as 2.5, 3.5, 4.5 or 7. For turning post, indicate roller type as either 196 or 251.

NOTE: TW is 24 hour shipment; TP is 2 week shipment.

TURNING POST ASSEMBLY

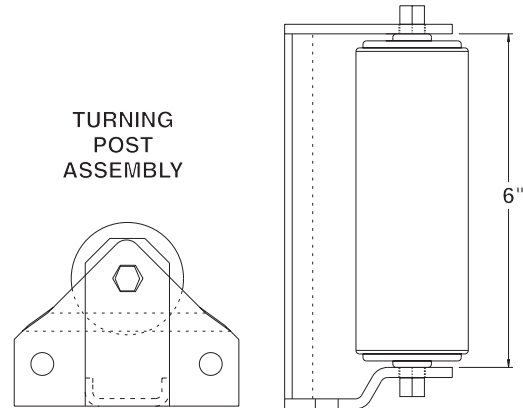

■ 24 hour shipment ■ 2 week shipment

MOTOR DRIVE ASSEMBLY

This is a complete 1/3 HP drive featuring Baldor motor and Boston reducer including motor, reducer, reducer mounting plate ("motor base"), No. 50 roller drive chain, chain guard with cover and two drive sprockets. Specify conveyor that drive mounts to for proper allocation of drive components.



SPECIFY MODEL NUMBER PER EXAMPLE

MDA-1/3-21-60

MDA-(horsepower)-(between frames*)-(speed)

*Conveyor model number and BF must be indicated for proper allocation of drive components

SPECIFICATIONS

MOTOR: Baldor 1/3 HP, 230/460/3, 60 cycle, ODP.

REDUCER: Boston, 30:1 ratio, right angle.

MOTOR BASE: Underneath mount with push plate for chain take-up.

SPEED: 60 FPM, constant.

104



■ 24 hour shipment